

REV.	DATE	DESCRIPTION	DRAWN
V1.0	01-05-23	DRAWING CREATED TO RECORD PRODUCTION-FITTED ASSEMBLY PROCESS AS SETTLED AFTER INITIAL SAMPLES.	ROSS DAWE
V1.1	05-09-23	RIVETS FOR STAINLESS PARTS CHANGED FROM 6-8 ALUMINIUM TO 6-6 STAINLESS. MATERIAL AND GRIP LENGTH CORRECTION.	ROSS DAWE
V1.2	13-03-24	WASHERS ADDED BEHIND SPAR ROD MOUNTS TO REINFORCE FIBREGLASS.	ROSS DAWE
V1.3	20-08-24	DRAWING UPDATED TO REFLECT CURRENT PRODUCTION: CUSTOM CAST MOUNTS SCREWED TO DRAWBAR REPLACE MODIFIED MOUNTS AND SEPARATE HOOKS PREVIOUSLY RIVETED IN PLACE. FABRICATED SPAR ROD JOINERS REPLACED WITH CUSTOM CAST PART.	ROSS DAWE

**ISOMETRIC VIEW - UNDERSIDE  
STANDARD '700mm' DRAWBAR CHASSIS SHOWN.**

**INSTALLATION NOTES:**

1. FIT SPAR-ROD MOUNTS TO DRAWBAR AS DETAILED ON DRAWING VIEW **DETAIL A**.
2. FIT SPAR-ROD MOUNTS TO NOSECONE AS DETAILED ON DRAWING VIEW **DETAIL B**.
3. FIT HOOKS TO FRONT OF CHASSIS CROSSMEMBER AS DETAILED IN DRAWING VIEW **SECTION E-E**.
4. FIT STONE SHIELD TO CAMPER USING MOUNTS AND HOOKS INSTALLED SO FAR. USE THE ADJUSTMENT STRAPS AT THE NOSECONE END TO PULL THE STONE SHIELD TAUT.
5. CONTINUE FITTING HOOKS AS DETAILED IN DRAWING VIEWS **DETAIL C** AND **DETAIL F**, CONFIRMING HOOK POSITION ON CHASSIS WITH THE STRAP AND D-RING POSITIONS SEWN TO THE STONE SHIELD.

**GENERAL:**

- IT MAY BE NECESSARY TO ENLARGE THE RIVET HOLES (USING A #12-#8, 3/16", 4.8mm OR 5mm DRILLBIT) IN THE HOOK CASTING TO CLEAR THE 6G (4.8mm) RIVETS SUPPLIED.
- SILICONE TO BE ADDED UNDER SPAR ROD MOUNTS ON NOSECONE TO PREVENT WATER INGRESS INTO BOOT/NOSECONE.
- DRAWING BOM SHOWN COVERS PHYSICAL ASSEMBLY-FITTED PARTS ONLY. SEWN MESH STONE SHIELD IS DRAWBAR LENGTH SPECIFIC. CHECK SYSTEM BOM FOR COMPLETE LIST OF COMPONENTS TO BE INCLUDED.

ITEM	QTY	DWG/PART No	SUPPLIER PART	DESCRIPTION	MATERIAL	WIDTH	LENGTH	VOLUME	WEIGHT
11	2	P00881		Stone Shield Spar Rod Tube - Joiner Coupling - Cast	Cast 316 Stainless Steel		100.00		103.89
10	6	Screw - Pan - Socket - 5mm - M5 x 0.8 - 12mm - A2-70 G304 SS	BOLT-M5x12-SS-BUT, 31BS512	Screw - Pan - Socket - 5mm - M5 - 120mm - A2-70 G304 SS					2.91
9	2	P00879		Stone Shield Mount - Custom Adjustable Cam Lock Antenna Base	Cast 304 / 316 SS with all stainless hardware				564.10
8	8	Washer - 4.76 - 19.05 - FLAT - SS - SFW31634B	SFW31634B	Washer - 3/16" - 3/4" - FLAT - 304 SS					
7	16	Rivet - 6-6 - Stainless Steel - Truss Head - 4059	4059	Rivet - 6-6 - All Stainless Steel - Truss Head					
6	8	Sunstar - Hook Catch Stay - SS - HOOK-SS - SS015-010	SS015-010	Sunstar - Hook Catch Stay - SS - HOOK-SS	Cast 304 SS				49.66
5	8	Rivet - 6-12 - Aluminium 5056 & Steel - Truss Head - 4045	4045	Rivet - 6-12 - Aluminium 5056 & Steel - Truss Head					
4	1	P00804		Spar Mount - Body - Right	Nylon 6				93.17
3	1	P00805		Spar Mount - Body - Left	Nylon 6				93.17
2	2	P00393		180 360 Safari Roof Spar Rod	Epoxy Fibreglass - 13mm - White		1750.00		
1	2	P00734		360 Safari Roof Spar Rod	Epoxy Fibreglass - 13mm - White		1650.00		

DO NOT SCALE DRAWING

UNLESS OTHERWISE SPECIFIED:  
 • Drawing is in Third Angle projection  
 • All dimensions are in millimetres  
 • Tolerances ±0.5mm (parts) ±1mm (assemblies), ±0.5°  
 • Debur and break sharp edges

PROPRIETARY and CONFIDENTIAL. Information contained in this drawing is the sole property of Ultimate Campers. Any reproduction in part or as a whole without the written permission of Ultimate Campers is prohibited.

NAME	SIGNATURE	DATE
DRAWN	ROSS DAWE	01-05-23
CHK'D		
APPV'D		
MFG		
Q.A		

QUANTITY: 1 PER CAMPER (OPT.)

MATERIAL:

FINISH:

WEIGHT: g

SCALE: 1:15

SHEET 1 OF 4

**ULTIMATE** OFF ROAD CAMPERS  
 39-41 Shelley Rd, Moruya, NSW 2537  
 T: 1300 500 077  
 W: www.ultimatecampers.com.au

CAMPER SERIES: X-SERIES - STONE SHIELD

DESCRIPTION: ASSEMBLY - Eagle Wing Stone Shield

DRAWING NAME: **A00121 1.3**

A3

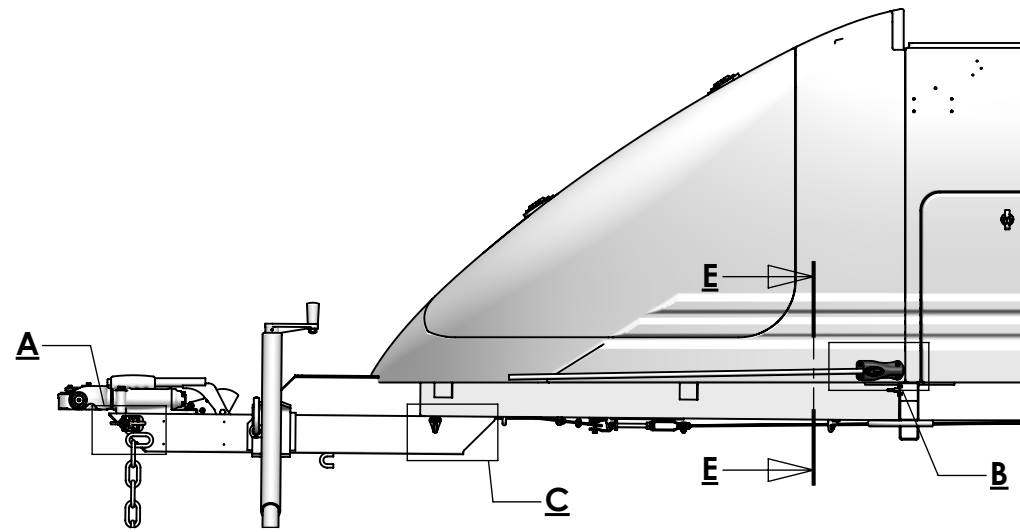

**KERBSIDE VIEW - CROPPED**

MARK, DRILL AND TAP ONE SCREW POSITION FIRST. SCREW MOUNT TO DRAWBAR, THEN ALIGN MOUNT AND MARK TWO REMAINING HOLES USING MOUNT AS A TEMPLATE.

**ADD LOCTITE 243 BLUE ON FINAL INSTALL!**

TOP EDGE FLUSH WITH EDGE OF DRAWBAR CORNER RADIUS.

DRILL  $\varnothing 4$  THRU TAP TO M5x0.8 TYP.

ANGLED FRONT EDGE OF CASTING POSITIONED FLUSH WITH FRONT OF DRAWBAR.

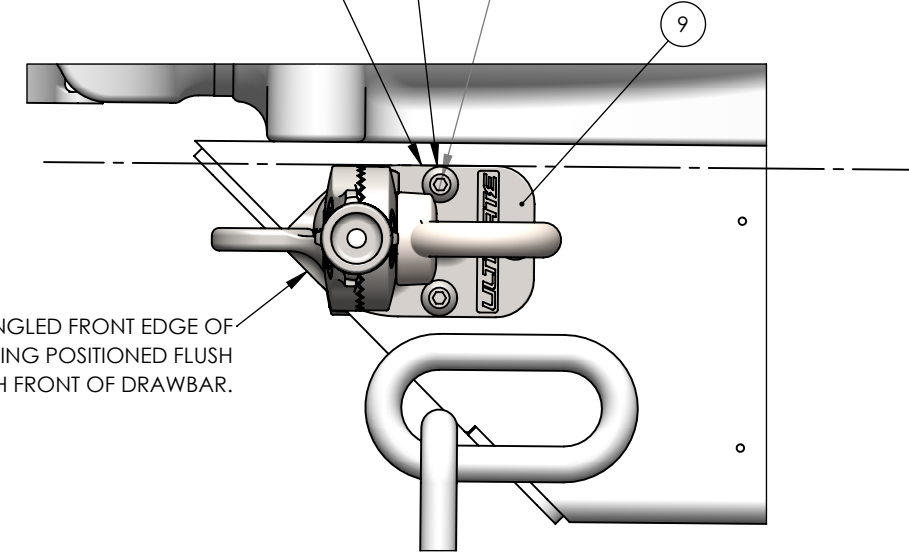

**DETAIL A  
FRONT SPAR-ROD MOUNTS ON DRAWBAR  
SCALE 1 : 2**

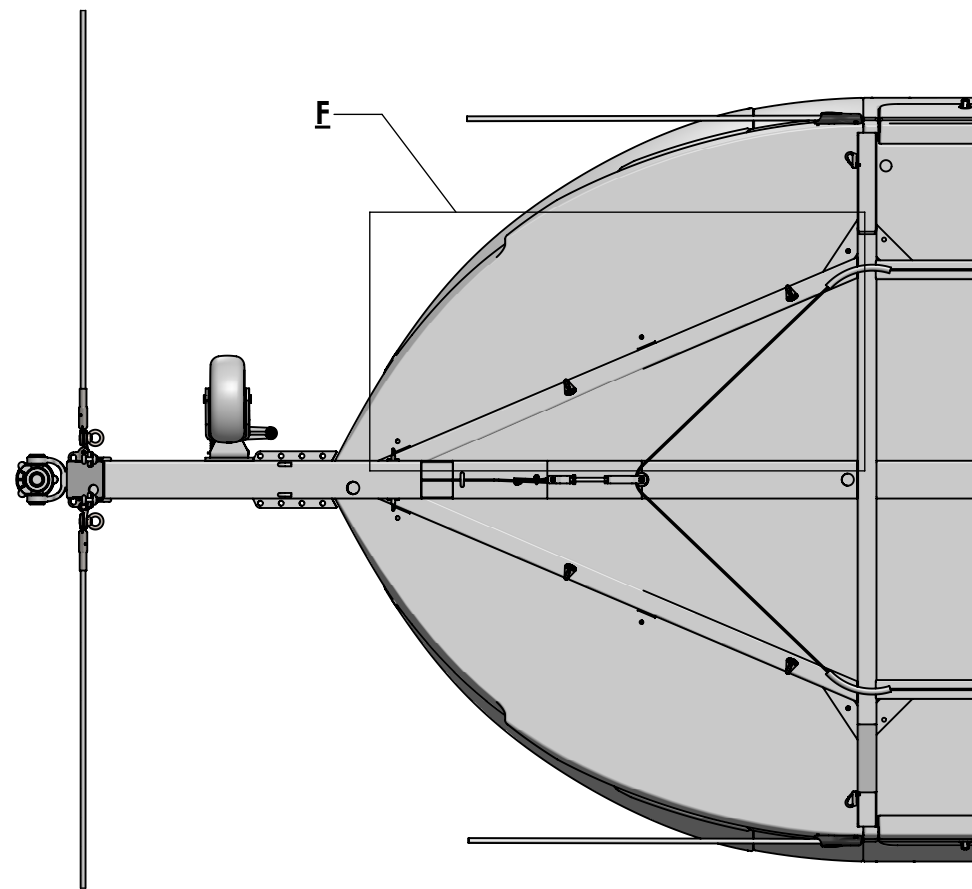

**UNDERSIDE VIEW - CROPPED**

NOTE THAT THESE MOUNTS ARE LEFT AND RIGHT SPECIFIC. LOGO TO BE UPRIGHT!

MARK AND DRILL THIS RIVET POSITION FIRST. RIVET MOUNT TO BODY, THEN ALIGN MOUNT AND MARK/DRILL THREE REMAINING HOLES USING MOUNT AS A TEMPLATE.

ADD SILICONE TO MOUNT/HOLES TO PREVENT WATER INGRESS INTO NOSECONE.

ADD WASHERS TO SPAR ROD MOUNT RIVETS INSIDE BOOT AREA TO REINFORCE FIBREGLOSS.

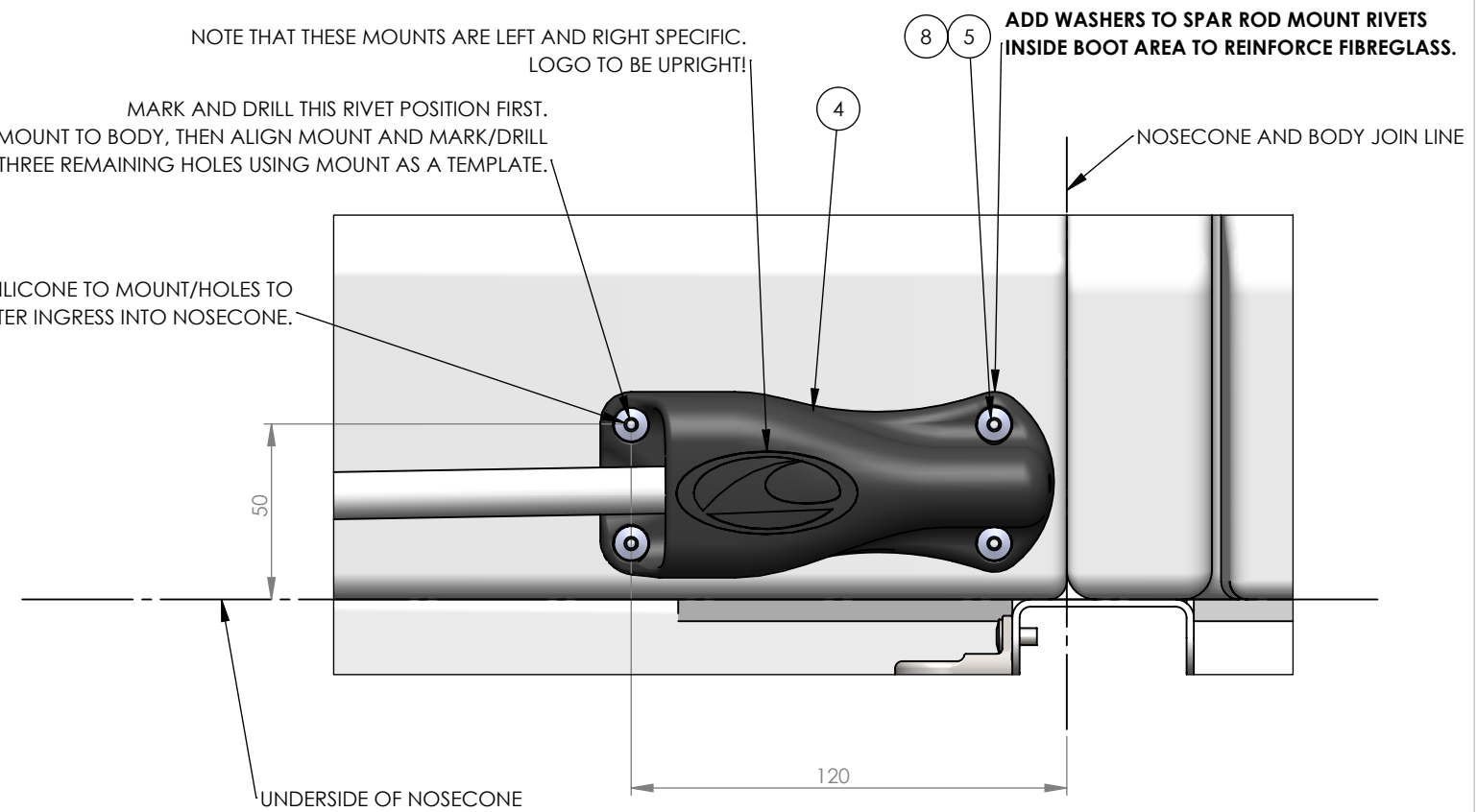

**DETAIL B  
REAR SPAR ROD MOUNTS ON BODY  
SCALE 1 : 2**

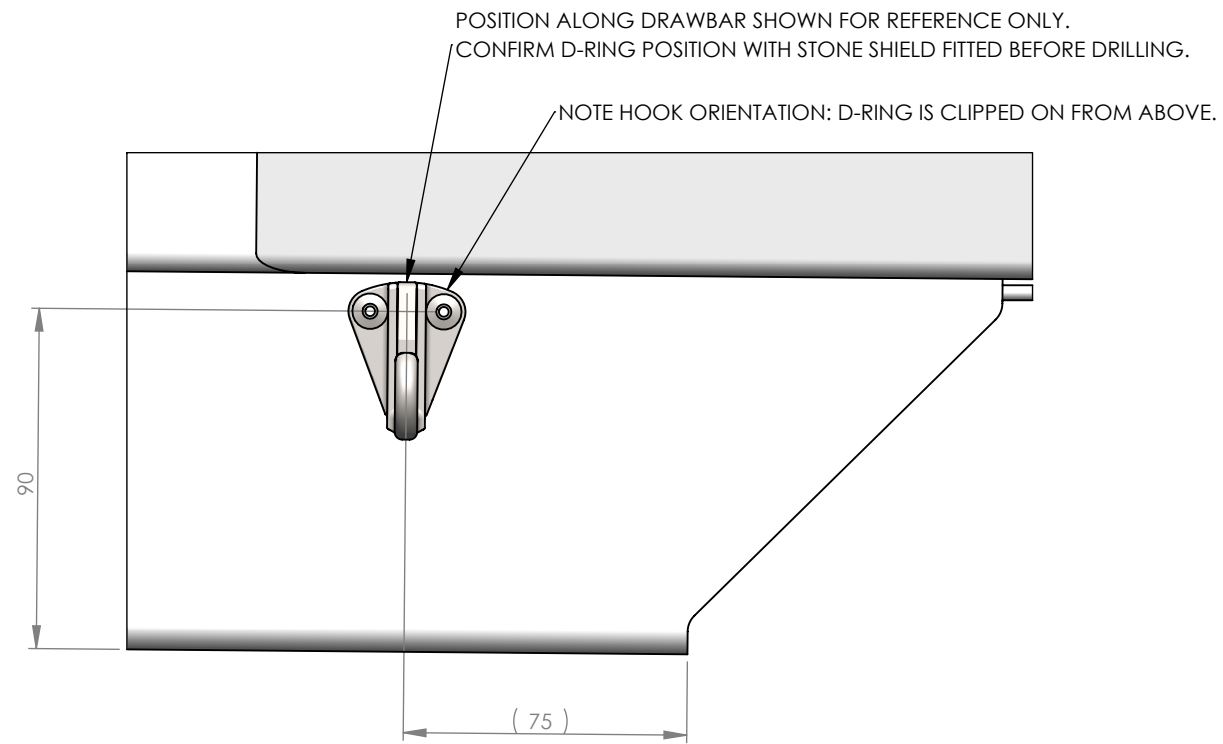

**DETAIL C**  
**HOOKS ON REAR OF LOWER DRAWBAR**  
**SCALE 1 : 2**

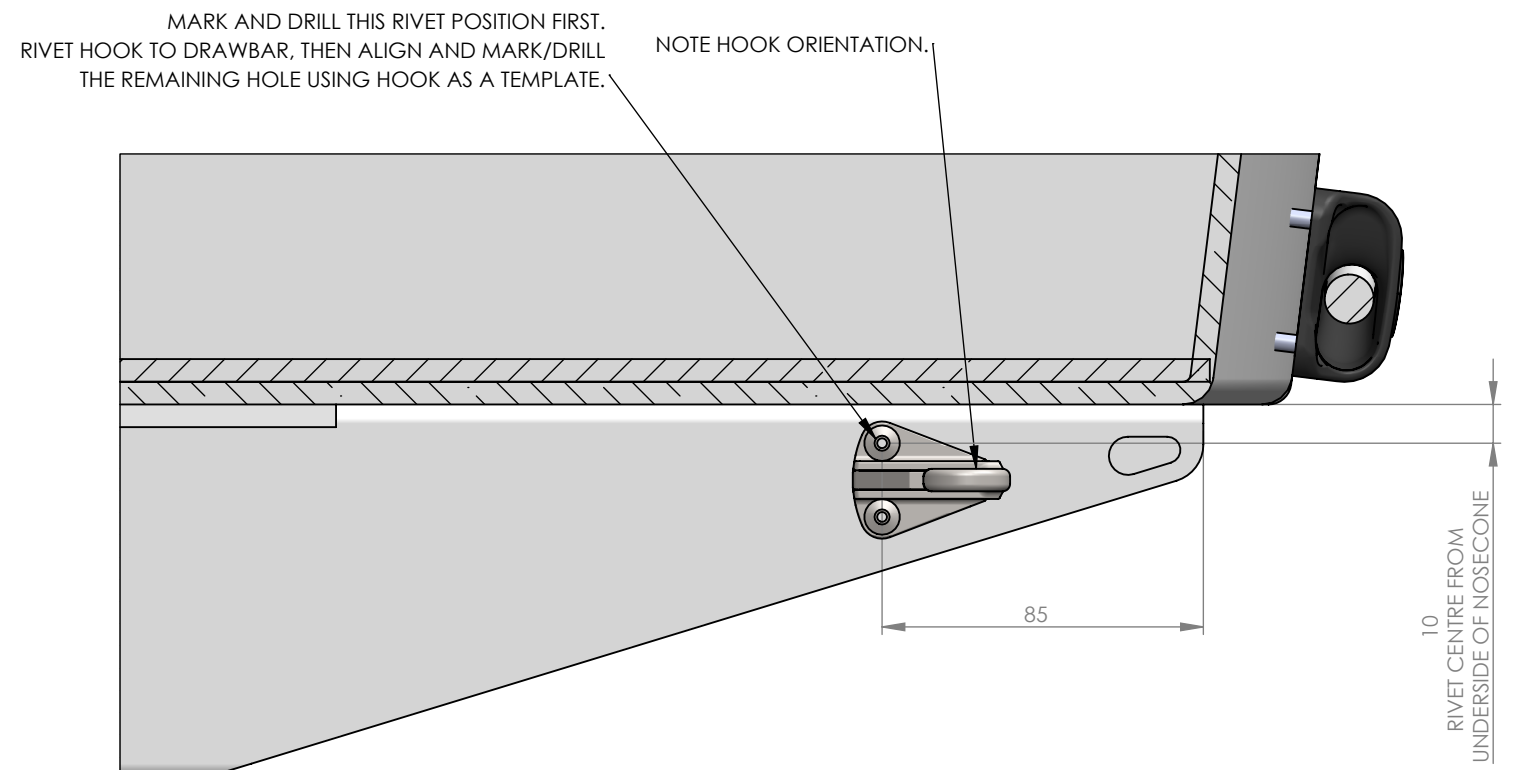

**SECTION E-E**  
**(CROPPED TO KERBSIDE)**  
**REAR HOOK ON FRONT CROSSMEMBER**  
**SCALE 1 : 2**

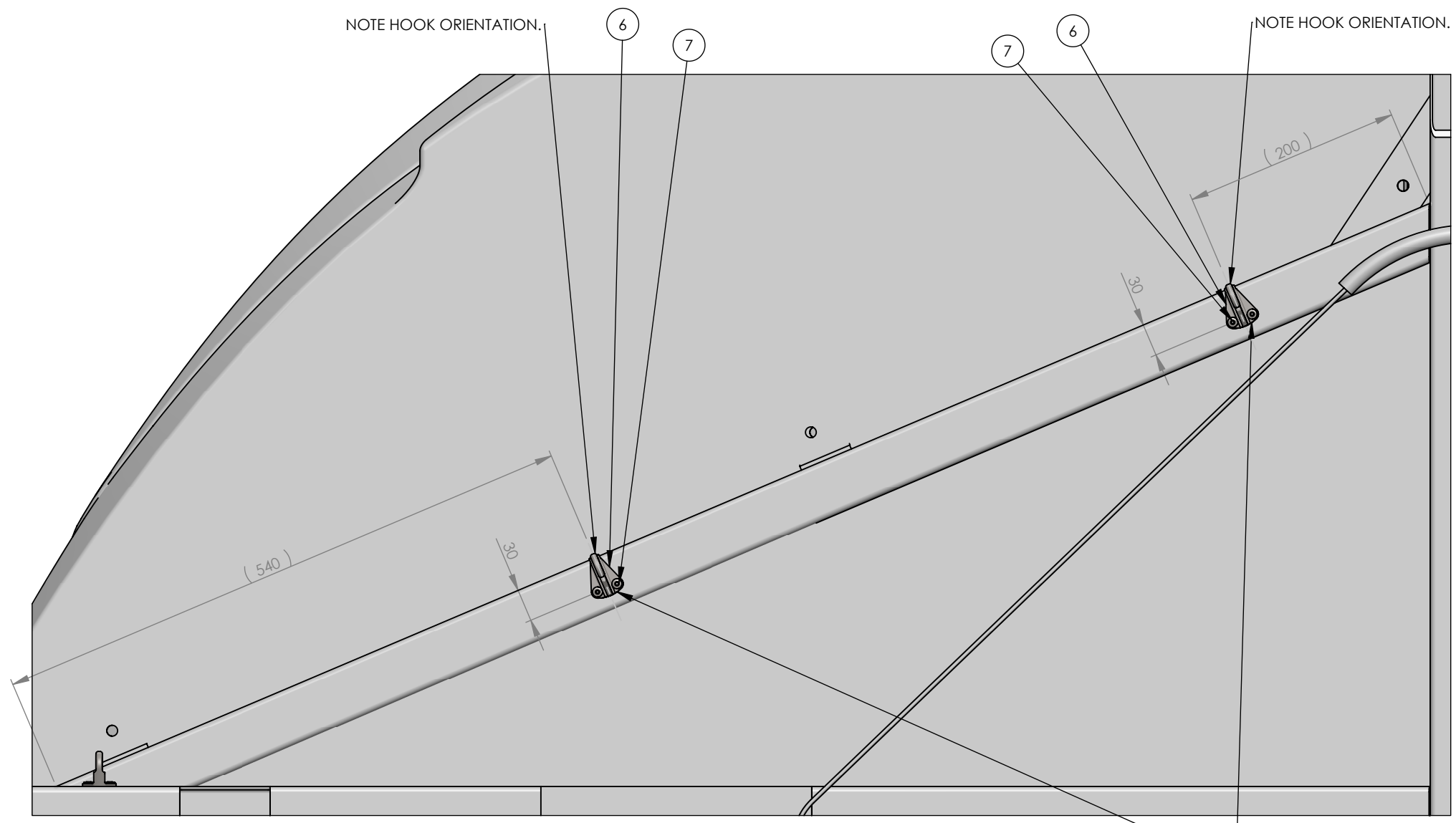

**DETAIL F**  
**UNDERSIDE VIEW - KERBSIDE (INSTALLATION MIRRORED FOR ROADSIDE)**  
**HOOK FITMENT ON CHASSIS DIAGONALS**  
**SCALE 1 : 5**

POSITION ALONG CHASSIS SHOWN FOR REFERENCE ONLY.  
 CONFIRM STRAP HOOK POSITIONS WITH STONE SHIELD FITTED BEFORE DRILLING.